

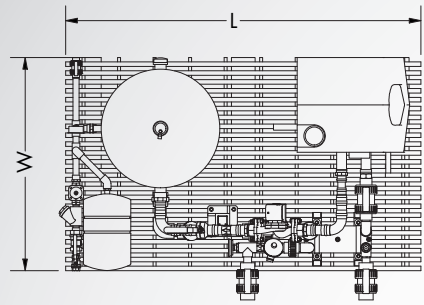

AQUATIC BOILER PACKAGE (110 000 - 800 000 BTUH)

HIGH EFFICIENCY HEATING PACKAGE FOR ALL AQUATIC HEATING APPLICATIONS



PLAN VIEW ABP-110 ~ 285

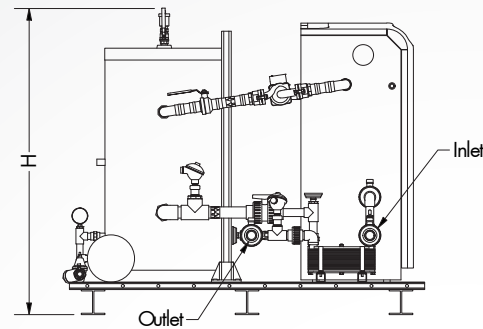

SIDE VIEW ABP-110 ~ 285

MODEL NUMBER	SPECIFICATION				DIMENSIONS					
	Max BTU Input	BTU Output Range	Δ PSI at Min flow	Water Flow Range (GPM)	Buffer Tank Size (Gal.)	Length (L)	Width (W)	Max. Height (H)	Connection Size	Shipping Weight (Lbs)
DH-ABP-110	110 000	10 450 - 104 500	<5	15 - 25	30	60"	36"	52"	1.5"	805
DH-ABP-155	155 000	14 725 - 147 250	<5	15 - 25	30	60"	36"	52"	1.5"	825
DH-ABP-200	200 000	18 999 - 199 999	<5	20 - 30	30	60"	36"	52"	1.5"	850
DH-ABP-285	285 000	27 075 - 270 750	<5	20 - 30	30	60"	36"	52"	1.5"	900
DH-ABP-400	400 000	74 613 - 373 065	<5	55 - 70	50	84"	48"	82"	2"	2080
DH-ABP-500	500 000	93 500 - 467 500	<5	65 - 80	50	84"	48"	82"	2"	2110
DH-ABP-600	600 000	112 200 - 561 000	<5	80 - 95	80	84"	48"	82"	2.5"	2140
DH-ABP-700	700 000	130 900 - 654 500	<5	95 - 110	80	84"	48"	82"	2.5"	2170
DH-ABP-800	800 000	149 600 - 748 000	<5	105 - 120	80	84"	48"	82"	2.5"	2200

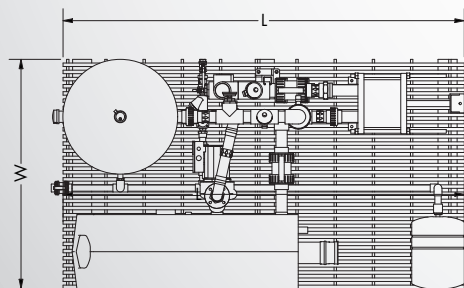

PLAN VIEW ABP-400 ~ 800

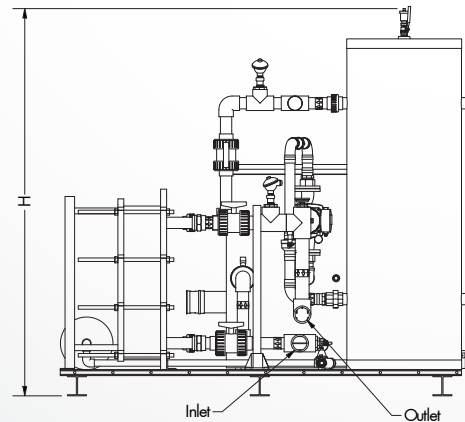

SIDE VIEW ABP-400 ~ 800

DH-ABP-285

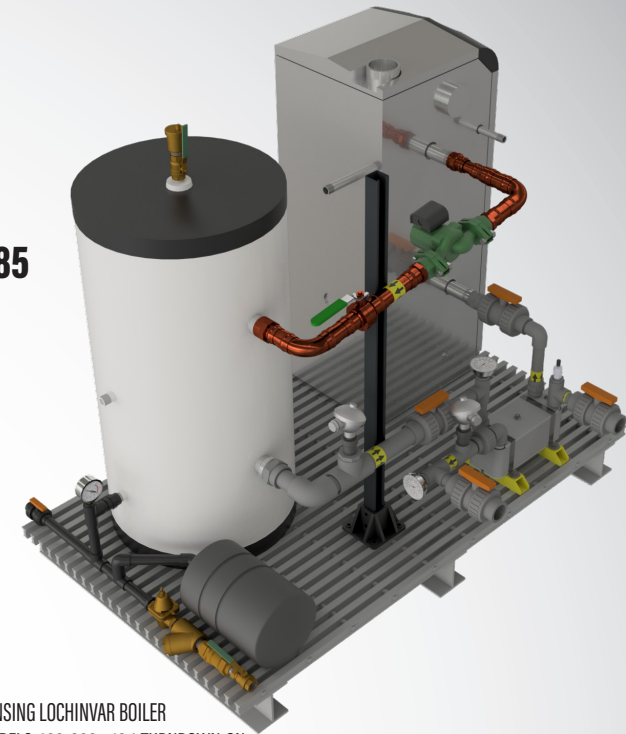

NOTES:

- 95% EFFICIENT CONDENSING LOCHINVAR BOILER
- 5:1 TURNDOWN ON MODELS 400-800 ; 10:1 TURNDOWN ON MODELS 110-285
- SCH80 CPVC & COPPER PIPING PACKAGE
- BUFFER TANK TO INCREASE BOILER EFFICIENCY AND LIFESPAN
- PLATE HEAT EXCHANGER WITH ALL 316SS HARDWARE
- TITANIUM OR 316SS PLATES DEPENDING ON APPLICATION
- EXPANSION TANK AND AIR VENT FOR SAFE OPERATION
- FLOW SAFETY SWITCHES
- FRP BASE SECURED WITH 316SS HARDWARE
- LIQUID PROPANE OR NATURAL GAS FIRED
- 120v / 1 Ph power on models 110 ~ 285
- 230v / 1 Ph power on models 400 ~ 800

DOES NOT INCLUDE:

- VENTING MATERIAL
- AQUATIC PUMP
- ELECTRIC AND GAS CONNECTIONS

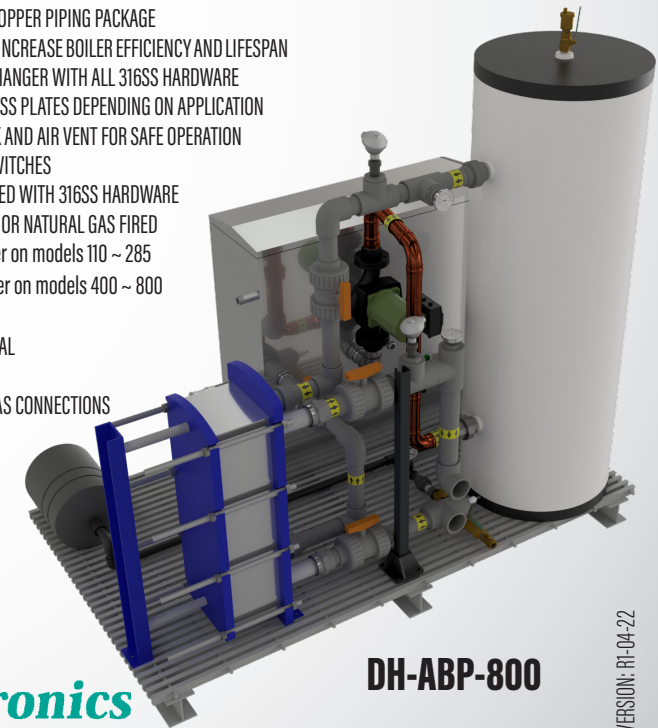

DH-ABP-800

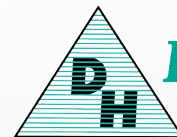

Delta Hydronics

9100 Bolton Ave., Hudson, FL, 34667 (727) 861-2421 - info@deltahydro.com